

CREASING AND PERFORATING

Perforating knife	11 TPI	17 / 26 TPI (optional)
Perforating blade	11 TPI	17 / 26 TPI (optional)
Creasing	Negative crease standard	Positive crease (optional)
Tool detection	Automatic	
Tool calibration	Automatic	Automatic setup of correct pressure and parallism
Creasing depths	3 different positions	Adjustable on screen
Creasing options	Turnable creasing bar with two options	Total of 6 creasing options
Creasing distance min.	1 mm	
Perforating distance min.	3 mm	
Perforating heads	1-4 (optional)	
Perforating distance* min.	30 mm	*Distance from head to head
Min. length of time perforation	5 mm	Programmable on screen
Number of time perforations	Up to 5	Programmable on screen

MORE THAN
4'000 CUSTOMERS
BELIVE IN OUR
TOUCHLINE MACHINES.
MULTIFINISHING
MAKES YOUR LIVE
EASIER.

**CUTTING, SLITTING,
PERFORATING & CREASING
ALL IN ONE PASS**

TOUCHLINE CPC375 XPRO

Up to 35'000 business cards/h
Length and cross perforation
Time perforation in both directions
Expandable with folding machine

DIMENSIONS AND WEIGHT TOUCHLINE CPC375 XPRO

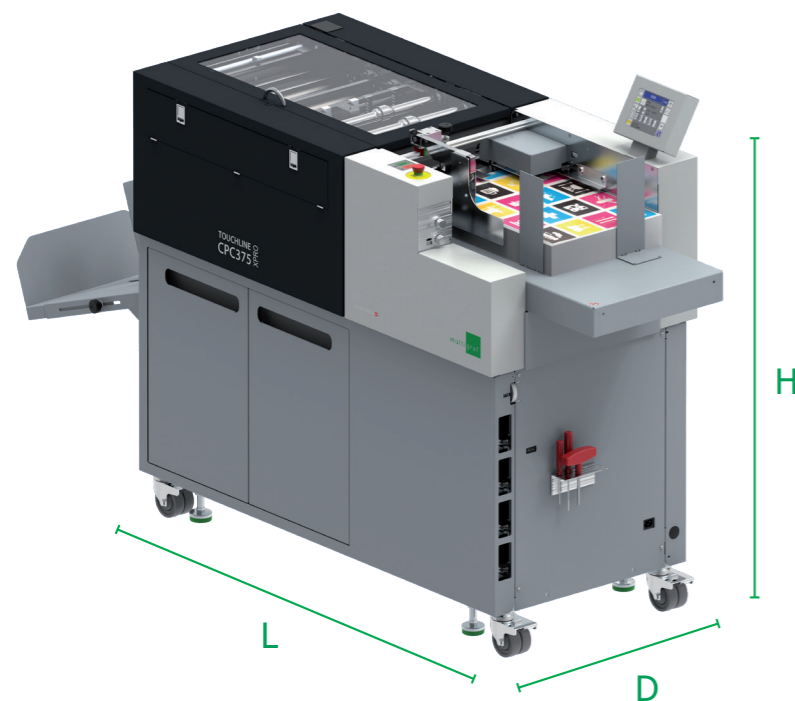

Dimensions
Length (L) 2'010 mm
Depth (D) 600 mm
Height (H) 1'200 mm

Weight
265 kg



**THE
REVOLUTION
IS
HERE**

Multigraf AG follows a policy of continuous improvement and reserves the right to modify the technical data provided in this document without prior notification. The production rates are based on optimum operating conditions and may fall depending on the usage and ambient conditions. Subject to technical modifications and errors.

MULTIFINISHING MAKES YOUR LIFE EASIER...

- ✓ Cutting, slitting, perforating and creasing in one pass!
- ✓ Time perforation in both directions
- ✓ Expandable with folding machine
- ✓ Length and cross perforations
- ✓ Up and down crease
- ✓ Dynamic job creator
- ✓ Barcode reader

SPECIFICATIONS CPC375 XPRO

Feeding system	Vacuum infeed belts
Feeder capacity	180 mm
Sheet size max.	375 x 660 mm* 375 x 1'050 mm**
Sheet size min.	105 x 180 mm
Finished size min.	50 x 80 mm
Paper stock creasing	100-400 g/m ² or up to 0,4 mm***
Paper stock perforating	80-300 g/m ² or up to 0,3 mm***
Paper stock cutting	80-400 g/m ² or up to 0,4 mm***
Job storage	200
Double sheet detection	Ultra sonic
Automatic job detection	Barcode reader
Image shifting	Register mark reader in development
Capacity of business card tray	3 x 100 mm / 1'000 cards (thickness 0,3 mm)
Deliveries	Delivery tray standard Business card module standard Stream delivery with stop and go function (optional)

*Standard **Optional table extension ***Depending on material quality

SPEED PRODUCTIVITY CHART

Input size	Finished size	X-up	Page per minute*	Remarks
SRA3	55 x 85 mm	21-up	19 ①	Each card with gutter
SRA3	55 x 85 mm	24-up	24 ②	Without gutter
SRA3	A3	1	39	1 crease
SRA3	A3	1	36	1 crease, 1 perforation
SRA3	A4	2-up	35	
SRA3	A5	4-up	35 ③	
SRA3	A5	4-up	32	1 crease (each card)
SRA3	A5	4-up	28	1 crease, 1 perforation (each card)
SRA3	A6	8-up	26	
360 mm	55 x 170 mm	10-up	33	Business card long, 1 crease
660 mm	630 mm	1	33	2 creases (triple A4)

CUTTING AND SLITTING

Cross cutter:		
Front edge	3 to 120 mm	
Trailing edge	3 to 80 mm	
Gutter cut	3 to 40 mm	
Slitting heads:		
Max. number of slitters	6	Fully automatic setting
Margin OP	3 mm to 70 mm	
Margin NOP	3 mm to 45 mm	
Gutter	5 mm to 25 mm	
Capacity of waste bin	88 liter (dm ³)	Possible to connect with a vacuum conveyor (optional)

①	SRA3		1'117 sheets/h x 21-up = 23'457 Business cards/h	Each business card with front, trailing edge trimm and gutter
②	SRA3		1'456 sheets/h x 24-up = 34'944 Business cards/h	Without gutter between business cards
③	SRA3		2'082 sheets/h x 4-up = 8'328 Greeting cards/h	Each greeting card with front, trailing edge trimm and gutter

*Number rounded off

DYNAMIC JOB CREATOR

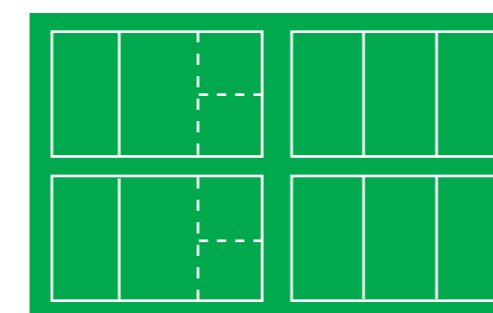

Input (SRA3)

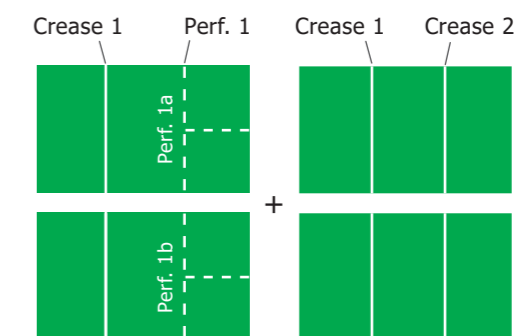

Finished x1 (A4)

Finished x2 (A4)